

S LUM MINI



LUMENIA
STREET

S LUM MINI LED svjetiljka je malih dimenzija, ali nudi mnogo u pogledu učinkovitosti i snage sustava. Izvrsno je za osvjetljavanje pješačkih područja, ulica i parkirališta.



	S LUM MINI		
Učinkovitost sustava*	Do 159 lm/W		
Napon napajanja	220-240 VAC		
Snaga	10 W	20 W	30 W
Svjetlosni tok	1590 lm	3185 lm	4580 lm
Faktor snage	>0,96		
Preporučena visina ugradnje	Do 6m		
Masa	4 kg		
Životni vijek L80B10	>100000 sati		
Korelirana temperatura boje (CCT)	4000K; drugi na zahtjev		
Indeks uzvratna boja (CRI)	≥70; ≥ 80 na zahtjev		
Zaštita od prodora	IP66		
Zaštita od mehaničkog udara	IK09		
Mogućnosti zaštite od prenapona	10 kV / 6 kV; dodatno SPD 10 kV / 10 kA		
Radna temperatura	-40 °C do +55 °C		
Razred električnog uređaja	Razred I, Razred II		
Nagib	-10° to 15°		
Razine intenziteta svjetla	0-100 %		
Mogućnosti daljinskog upravljanja	Izborni RF ili PLC		
Boja (RAL)	RAL 7037		
Materijal kućišta	Aluminij		
Montaža	Stup 60 mm ili 76 mm		
Jamstvo	5 godina		
Certifikati	IEC 60598-1:2014 (8th edition); IEC 60598-2-3:2002 + A1:2011; EN 60598 - 1:2015; EN 60598-2-3:2003 + A1:2011; IEC/EN 62031:2008 + A1 + A2; IEC/TR 62778:2014; EN60068-2-6: N60068-2-27:CE, ENEC, LM79, IES LM-82-12		

* +/- 10%, ovisi o koreliranoj temperaturi boje i indeksu uzvratna boja.

INAČICA	Economy	Standard	Premium
Učinkovitost	Do 130 lm/W	Do 159 lm/W	Do 159 lm/W
Pristup bez alata	Ne	Da	Da
Zaštita od pregrijavanja	Ne	Da	Da
Broj optike	5		
Dostupni su različiti CCT-ovi	2200K - 5700K CRI70 / CRI80		
Regulacija intenziteta svjetla po izboru	Ne	DALI, prilagodba svjetlosti u 5 koraka, LCO	DALI, System Ready, prilagodba svjetlosti u 5 koraka, Zhaga, LCO
Vremenski ovisan svjetlosni tok	Ne	Da	Da
Vanjski SPD 10kV / 10kA integriran	Ne	Ne	Ne
Dodatne mogućnosti	Vanjski SPD 10kV / 10kA	Vanjski SPD 10kV/10kA, PLC, bežično upravljanje, spremno za sustav Nema	Vanjski SPD 10kV/10kA, PLC, bežično upravljanje



Opcija upravljanja



Učinkovitost sustava



LED modul



Proizvod koji šteti energiju



Pametni driver



Zaštita od preopterećenja



Napon napajanja



Uređaj za zaštitu od prenapona



Razred zaštite



Zaštita od udara



Dug životni vijek



Razred uređaja I



Razred uređaja II



Jednostavna montaža



Proizvedeno u EU



Zatamnjene u 5 koraka



CE certifikat



Materijali koji se mogu reciklirati



ENEC certifikat

GLAVNE ZNAČAJKE

Jednostavan za ugradnju
Konstantni izvor svjetla
Otvaranje kućišta bez alata

PRIMJENA

Područja za pješake
Ulice
Parkirališta

DODATNA OPREMA

Driver pripremljen za sustav
Prekidač
PLC / RF upravljanje
Uređaj za zaštitu od prenapona (SPD)
Konektor Nema
Konektor Zhaga

DIMENZIJE

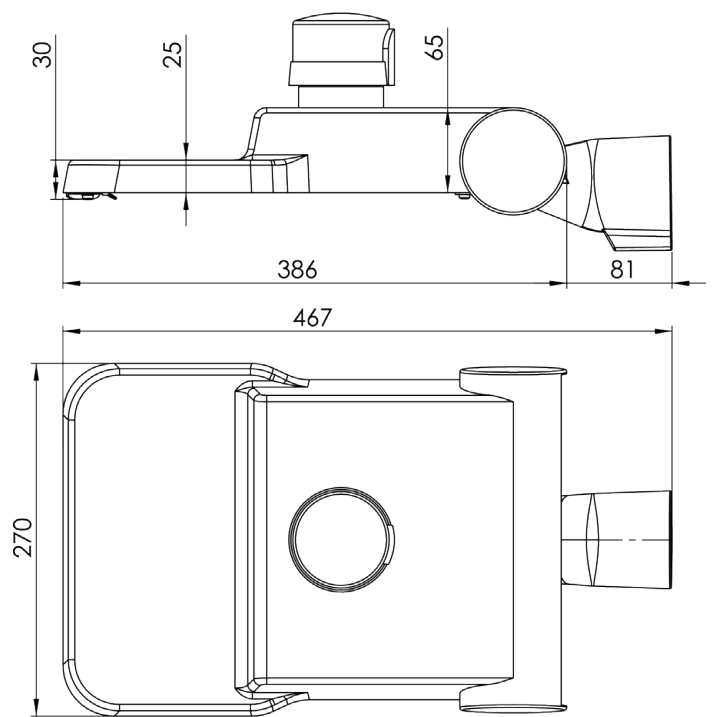

*Sve dimenzije izražene su u mm

OPTIKA

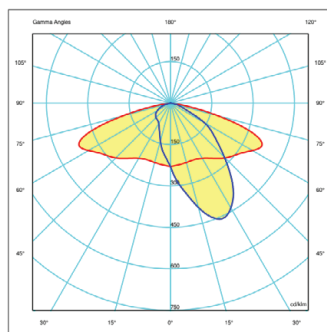

002: Pogodno za uže prometnice, prilazne ceste, biciklistička i pješaka područja.

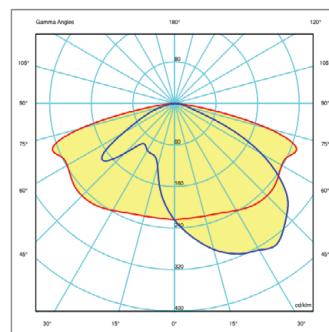

003: Pogodno za šire prometnice s velikim udaljenostima između stupova.

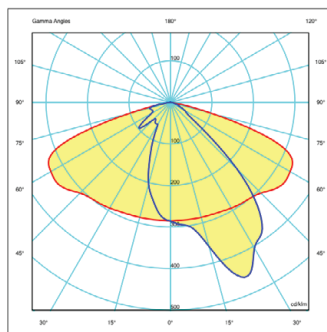

020: Pogodno za šire prometnice s velikim udaljenostima između stupova.

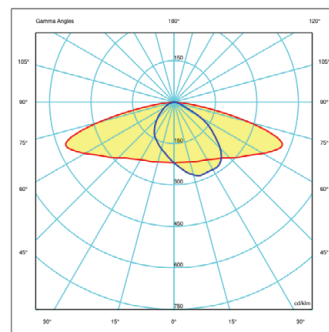

220: Pogodno za široke prometnice i velike udaljenosti između stupova.

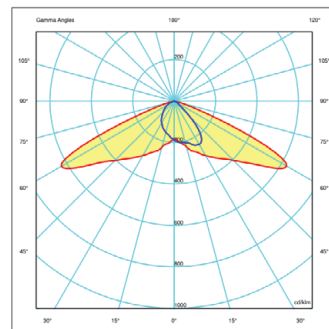

222: Pogodno za široke prometnice i velike udaljenosti između stupova.

INAČICE PROIZVODA

Economy

Artikl	Snaga [W]	Svjetlosni tok [lm] *	Učinkovitost [lm/W]	Dodatne mogućnosti
SME.F.SA.64.010_ _ _	10	Do 1300	130	SPD
SME.F.SA.64.020_ _ _	20	Do 2600	130	SPD
SME.F.SA.64.030_ _ _	30	Do 3900	130	SPD

Standard

Artikl	Snaga [W]	Svjetlosni tok [lm] *	Učinkovitost [lm/W]	Dodatne mogućnosti
SMS.T.SA.32.010_ _ _	10	Do 1590	159	SPD, PLC, RF, pripremljeno za sustav Nema
SMS.T.SA.64.020_ _ _	20	Do 3181	159	SPD, PLC, RF, pripremljeno za sustav Nema
SMS.T.SA.64.030_ _ _	30	Do 4579	153	SPD, PLC, RF, pripremljeno za sustav Nema

Premium

Artikl	Snaga [W]	Svjetlosni tok [lm] *	Učinkovitost [lm/W]	Dodatne mogućnosti
SMPT.SA.32.010_ _ _	10	Do 1590	159	SPD, PLC, RF, pripremljeno za sustav Zhaga
SMPT.SA.64.020_ _ _	20	Do 3181	159	SPD, PLC, RF, pripremljeno za sustav Zhaga
SMPT.SA.64.030_ _ _	30	Do 4579	153	SPD, PLC, RF, pripremljeno za sustav Zhaga

*Svjetlosni tok vrijedi za CCT 4000 K

Najnoviji potvrđeni podaci dostupni su na www.lumenia-adriatic.com.